

**BOON EDAM**
YOUR **ENTRY** EXPERTS.



BOONASSIST TQ.

THE USER-FRIENDLY, MANUAL REVOLVING DOOR



OVERVIEW

The BoonAssist TQ is our most user-friendly revolving door with three unique features that make it a modern door that is easy to use for all.

- **Power assist** allows the door to rotate easily with just a gentle push, making it easy to use for children and the elderly.
- **Speed control** ensures the door never spins out of control.
- **Positioning** guarantees the door always completes rotation with the door wings at the end posts. This position is intuitive for users stepping up to use the door, and also maximizes the seal that protects the interior from drafts, noise and pollution.

A SUSTAINABLE SOLUTION

Revolving doors are the most energy efficient entrance solutions available today. The always open, always closed principle of a revolving door ensures that the conditioned inside air and the unconditioned outside air remain separated, preventing drafts, dust and noise from entering the building. As less energy is required to maintain the conditioned climate inside the building, revolving doors help reduce the carbon footprint of a building and save both energy and cost.

The same effect can be reached by installing a double door vestibule. However, for double door vestibules with conventional sliding or swinging doors to be truly effective, both sets of doors should never be open at the same time.

This requires making vestibules that are very deep so that the operation of the doors are sequential. This can take up excessive space inside a building that could be used more productively. In addition, when there is bi-directional traffic using the same vestibule, it is likely that both doors will remain open at the same time allowing extreme infiltration to occur. The advantage of revolving doors is that they have a relatively small footprint and save energy while facilitating a continuous flow of people.

KEY FEATURES

- 3-Wing or 4-Wing configuration
- Manual, low energy operation
- Vertical pushbars
- Power-assist and speed control
- Positioning / quarterpointing
- Horsehair or felt weatherstripping
- Floor frame / matwell ring

KEY BENEFITS

- Saves on energy bills by being always closed, yet always open
- Reduced air infiltration when compared to swinging or sliding doors
- Maximizes use of valuable floor space
- Elevates the brand with an upscale look and feel
- Customizable in terms of finishes and building connection options

SUGGESTED SEGMENTS

- Corporate office buildings
- Retail stores
- Restaurants
- Hotels



You can level up in any of these categories:

- THROUGHPUT
- SECURITY
- SAFETY
- AESTHETICS
- TECHNOLOGY
- COMFORT
- SERVICE

LEVEL UP



If our standard specifications do not quite suit your needs, we open up opportunities for you to 'Level Up' where it counts most. You can also do this according to your most motivating value driver:

The specification table shows you our standard product options, and to the right of these, you can easily see, and consider, any compatible 'Level Up' options for fine-tuning the BoonAssist TQ.





A



B

A: BoonAssist Crystal, all-glass model
B: BoonAssist TQM, framed model

TECHNICAL SPECIFICATIONS

 THROUGHPUT	STANDARD	LEVEL UP OPTIONS
Throughput	20 - 25 People per minute	
Diameter	6' 6" - 10' 0" / 1985 mm - 3050 mm	
Height Under Canopy	7' 0" - 10' 0" / 2135 mm - 3050 mm	
Canopy Height	TQM framed model = 8"-12" / 203.2 mm - 304.8 mm Crystal all-glass model = 11/16" / 18 mm	
Throat Opening	3' 0" - 7' 0" / 1010 mm - 2110 mm	
Number of Doors / Wings	3 or 4	
 SECURITY	STANDARD	LEVEL UP OPTIONS
External Night Locking Doors	-	Bi-parting, sliding doors enclose door's throat opening after-hours
Remote Locking	-	Door wings complete rotation, position and lock via remote signal
Emergency Lockdown	-	Instantly lock door wings via remote push button to prevent intrusion
Access Control Integration	-	Requires remote locking and allows for integrated reader for after-hours access
 SAFETY	STANDARD	LEVEL UP OPTIONS
Speed Control	Ensures the door never spins out of control	
Emergency Egress	Collapsible door set	
Fire Alarm	Collapsible door set	
Safety Glass	Tempered safety glass	Laminated safety glass, vandal-resistant glass (UL 972)
 AESTHETICS	STANDARD	LEVEL UP OPTIONS
Finish	TQM framed model = anodized aluminum Crystal all-glass model = stainless steel #4	Additional finishes available upon request
Glass	Clear	Tinted, low iron, decals, etc. available upon request
Canopy Cover	TQM framed model = black HDPE Crystal all-glass model = tempered, laminated glass	TQM framed model = cover to match door finish, weather-resistant HDPE system
Floor Mat and Trim	Crystal all-glass model = matwell trim	TQM framed model = matwell trim optional Both models = floor grating, flooring and mats provided by others
Door Handles	Vertical push bars	
 TECHNOLOGY	STANDARD	LEVEL UP OPTIONS
Drive Unit Installation	TQM framed model = in ceiling or floor Crystal all-glass model = in floor only	
 COMFORT	STANDARD	LEVEL UP OPTIONS
Lighting	TQM framed model = LED overhead lights Crystal all-glass model = n/a	
Power Assist	Low energy motor provides automatic rotation after a gentle push	
Positioning	Quarterpointing ensures the door wings stop in a set position every time	

WORKING PRINCIPLE

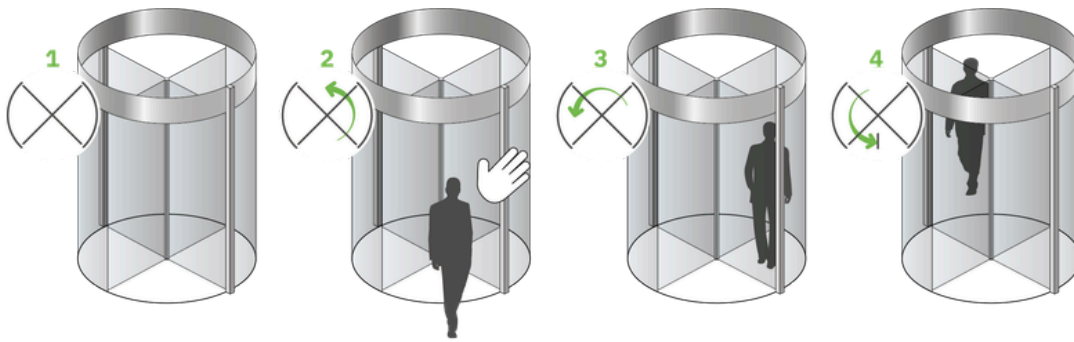

COLLAPSIBLE DOOR SET DURING FIRE ALARM

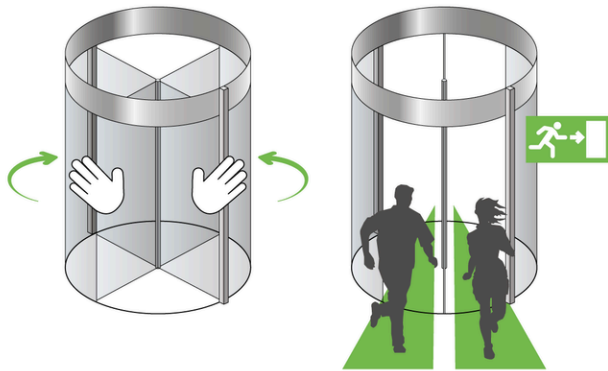

RESET DOOR WINGS AFTER FIRE ALARM

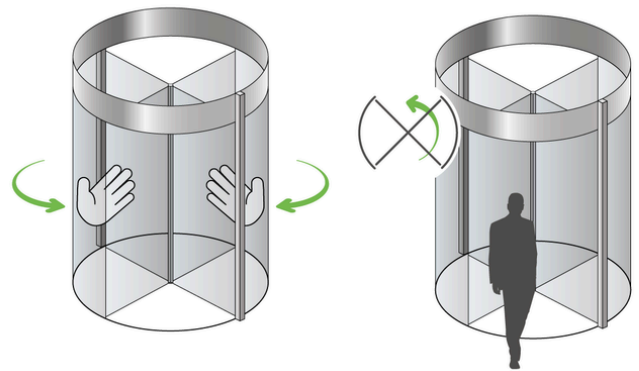

TECHNICAL DIMENSIONS

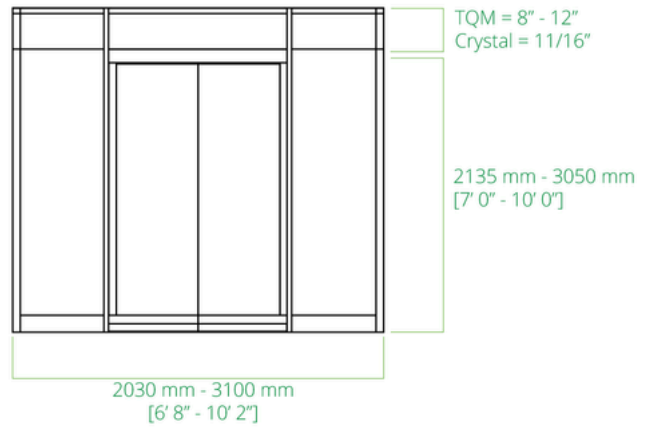
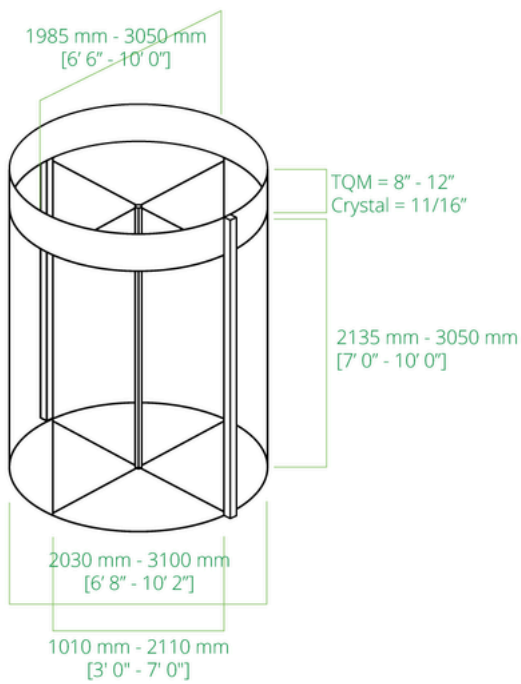



SERVICE AND MAINTENANCE

With hundreds or thousands of visitors passing through an entry every day, continued and reliable operation is vital. Regular service and maintenance can prevent unexpected hardware breakdowns. Boon Edam's service and maintenance teams across the world are experienced in the effects the local conditions have on the wear and tear of your entry solutions and can offer specialized service and maintenance contracts that correspond to those conditions perfectly.

COMPLIANCE

Boon Edam entrances are trusted solutions that allow organizations to meet compliance regulations related to restricting access to areas within a building. We take compliance and safety very seriously and ensure that our products are manufactured, installed and maintained to keep up the strict criteria required in all our countries. We are always improving and committed to making sure our products are compliant and certified. More information can be found on our website under 'About Us'.

The BoonAssist TQ complies with the following North American standards:

- UL 325
- CSA standard 22.2



OUR REACH IS GLOBAL.

We have been in business for 150 years manufacturing premium aesthetic and security entrance solutions in the Netherlands, United States of America and China. We can confidently say that we cover every corner of the globe with subsidiary companies in major cities across the globe. Furthermore our global export division not only partner with our distributors, but also offer direct sales and service to every territory. This wide net allows us to have a strong global footprint as well as a personal grasp of local markets and their unique entry requirements.

To find your closest Boon Edam expert, please go to:
www.boonedam.us/contact



Boon Edam Inc.
T +1 910 814 3800
E sales@boonedam.us
I www.boonedam.us

BOON EDAM
YOUR ENTRY EXPERTS.